

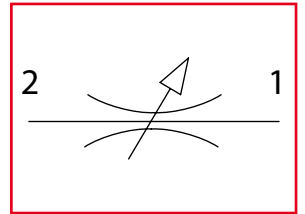

STB-BSP

Valvole di controllo flusso bidirezionali
Bidirectional flow control valves



Dati tecnici Technical data	
Viscosità fluido Fluid viscosity	10-500 mm ² /s 45 to 2000 ssu (6 to 420 cSt)
Classe di contaminazione Filtration	ISO code 16/13 SAE class 4 or better
Temperatura fluido Fluid temperature	-20°C +80°C -4°F +176°F
Temperatura ambiente Ambient temperature	-20°C +50°C -4°F +122°F

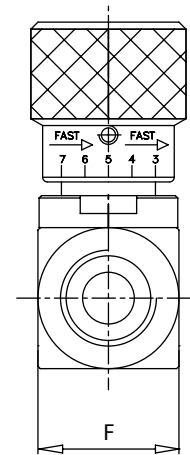
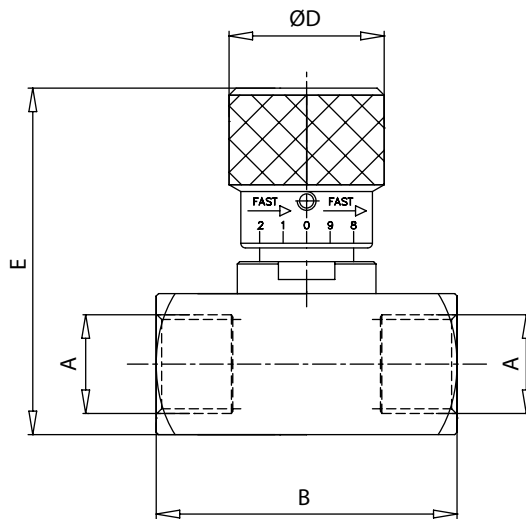
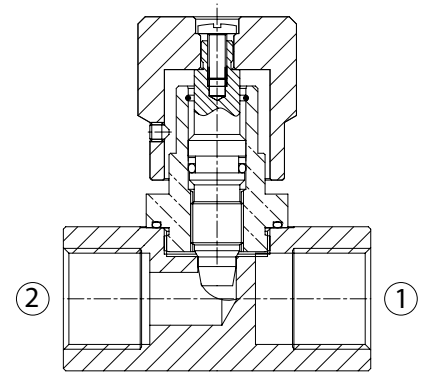

mm
(Inches)

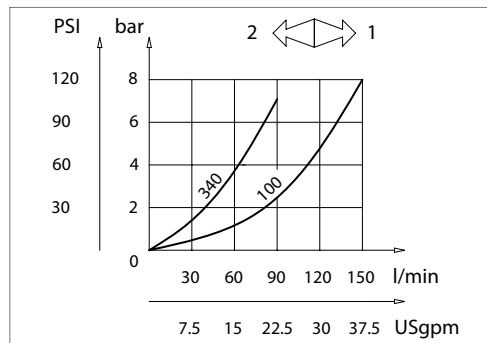
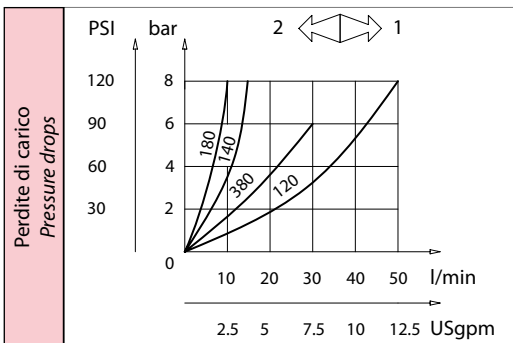

Caratteristiche tecniche Technical performances								
Codice Code	A	Portata Max Max flow l/min - USgpm	Pressione Max Max pressure bar/PSI	B	D	E	F	Peso approssimativo Approx weight Kg / lb
STB180	BSPP 1/8	10 (2.5)	400 (5800)	48 (1.89)	20 (0.79)	53 (2.08)	20 (0.79)	0,16 (0.35)
STB140	BSPP 1/4	15 (4)		54 (2.13)	30 (1.18)	68 (2.68)	25 (0.98)	0,29 (0.70)
STB380	BSPP 3/8	30 (8)		64 (2.52)	33 (1.30)	72 (2.83)	30 (1.18)	0,27 (0.64)
STB120	BSPP 1/2	50 (13)		81 (3.19)	42 (1.65)	94 (3.70)	40 (1.57)	1,02 (2.25)
STB340	BSPP 3/4	80 (20)		102 (4.02)		99 (3.90)	45 (1.77)	1,38 (3.04)
STB100	BSPP 1	150 (40)						

Codice ordinazione Ordering code	
STB-X	
X	Dimensione / Size
180	BSPP 1/8
140	BSPP 1/4
380	BSPP 3/8
120	BSPP 1/2
340	BSPP 3/4
100	BSPP 1



STB-NPTF

Valvole di controllo flusso bidirezionali
Bidirectional flow control valves

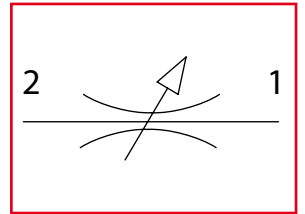

Dati tecnici Technical data	
Viscosità fluido Fluid viscosity	10-500 mm ² /s 45 to 2000 ssu (6 to 420 cSt)
Classe di contaminazione Filtration	ISO code 16/13 SAE class 4 or better
Temperatura fluido Fluid temperature	-20°C +80°C -4°F +176°F
Temperatura ambiente Ambient temperature	-20°C +50°C -4°F +122°F

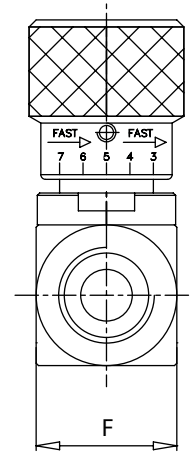
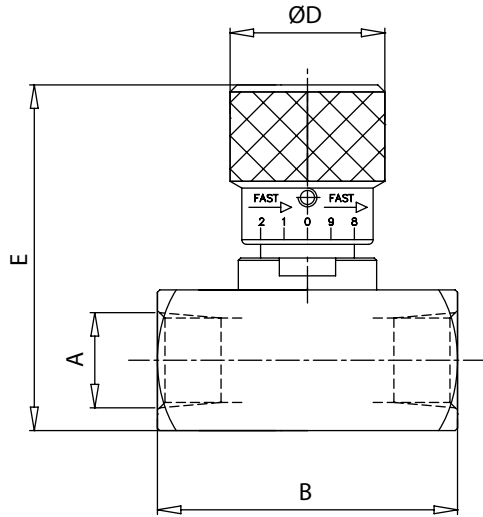
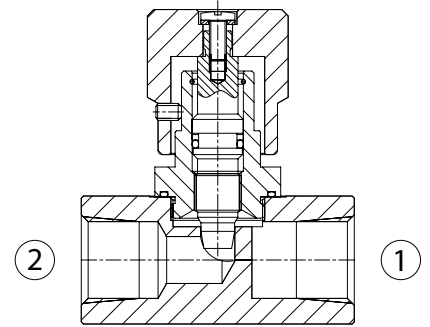

[mm
(Inches)]

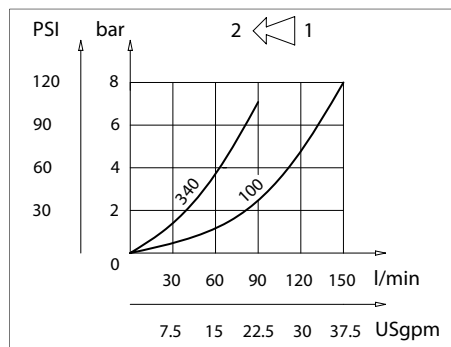
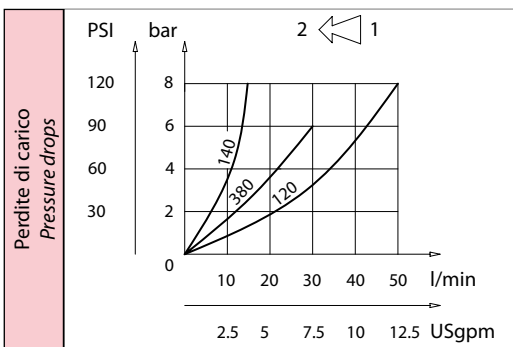

Caratteristiche tecniche Technical performances								
Codice Code	A	Portata Max Max flow l/min - USgpm	Pressione Max Max pressure bar/PSI	B	D	E	F	Peso approssimativo Approx weight Kg / lb
STB140NPTF	NPTF 1/4	15 (4)	400 (5800)	54 (2.13)	30 (1.18)	68 (2.68)	25 (0.98)	0,32 (0.71)
STB380NPTF	NPTF 3/8	30 (8)		64 (2.52)	33 (1.30)	72 (2.84)	30 (1.18)	0,30 (0.66)
STB120NPTF	NPTF 1/2	50 (13)		81 (3.19)	42 (1.65)	94 (3.70)	40 (1.57)	1,10 (2.43)
STB340NPTF	NPTF 3/4	80 (21)		102 (4.02)		99 (3.90)	45 (1.77)	1,50 (3.31)
STB100NPTF	NPTF 1	150 (40)						

Codice ordinazione Ordering code	
STB-X-NPTF	
X	Dimensione / Size
140	BSPP 1/4
380	BSPP 3/8
120	BSPP 1/2
340	BSPP 3/4
100	BSPP 1



STB-SAE

Valvole di controllo flusso bidirezionali
Bidirectional flow control valves

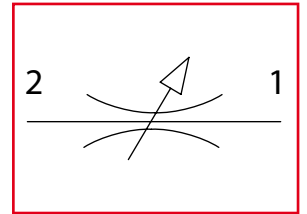

Dati tecnici Technical data	
Viscosità fluido Fluid viscosity	10-500 mm ² /s 45 to 2000 ssu (6 to 420 cSt)
Classe di contaminazione Filtration	ISO code 16/13 SAE class 4 or better
Temperatura fluido Fluid temperature	-20°C +80°C -4°F +176°F
Temperatura ambiente Ambient temperature	-20°C +50°C -4°F +122°F

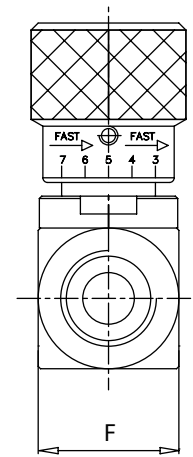
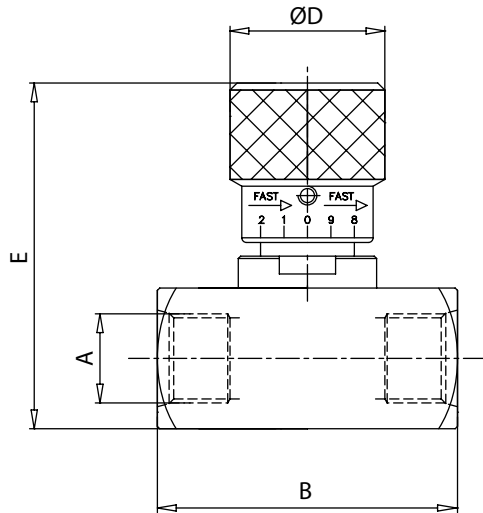
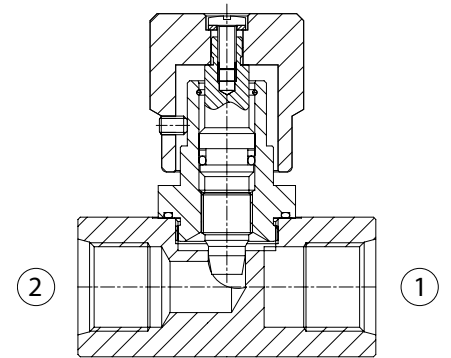

mm
(Inches)

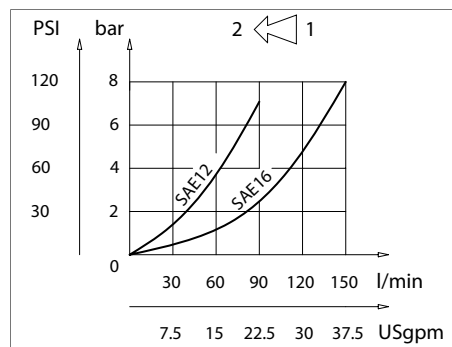
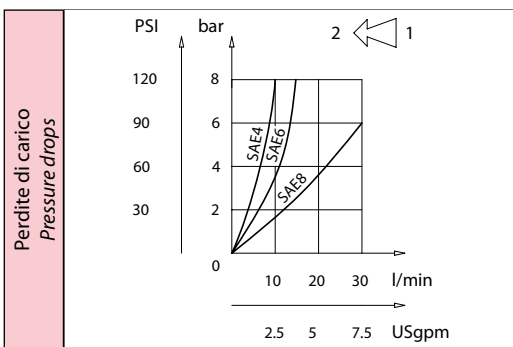

Caratteristiche tecniche Technical performances								
Codice Code	A	Portata Max Max flow l/min - USgpm	Pressione Max Max pressure bar/PSI	B	D	E	F	Peso approssimativo Approx weight Kg / lb
STB4SAE	7/16 - 20UNF	15 (4)	400 (5800)	54 (2.13)	30 (1.18)	68 (2.68)	25 (0.98)	0,32 (0.71)
STB6SAE	9/16 - 18UNF	30 (28)		64 (2.52)	33 (1.30)	72 (2.83)	30 (1.18)	0,30 (0.66)
STB8SAE	3/4 - 16UNF	50 (13)		81 (3.19)	42 (1.65)	94 (3.70)	40 (1.57)	0,45 (0.99)
STB12SAE	1 - 1/16 - 12UNF	80 (21)		102 (4.02)	99 (3.90)	45 (1.77)	1,10 (2.43)	
STB16SAE	1 - 5/16 - 12UNF	150 (40)					1,50 (3.31)	

Codice ordinazione Ordering code	
STB-X-SAE	
X	Dimensione / Size
4	7/16 - 20UNF
6	9/16 - 18UNF
8	3/4 - 16UNF
12	1 - 1/16 - 12UNF
16	1 - 5/16 - 12UNF